



Atosa is dedicated to making the kitchen better through innovation, quality and service. Come join us and see what new things we have in store for this year.

ABOUT US

Atosa is a major manufacturer of commercial kitchen equipment, with a breadth of offering including refrigeration, cooking equipment, warming/holding equipment, stainless steel fabrication equipment, and much more. Atosa's world class manufacturing facilities and highly skilled employees, combined with our innovative manufacturing procedures ensure that our customers always receive top quality products at economical prices.

WHY ATOSA?

- Wide breadth of product offering
- Premium quality products at value price
- Distribution facilities nationwide
- Exceptional customer service before & after the sale
- Averages over \$70 million of inventory at all times
- Excellent aftermarket services
- After-warranty technical support & service dispatch options
- Extended warranty options of up to 5 years parts & labor

DID YOU KNOW?

- Atosa works with 6,300 third-party service providers and has over 40 in-house service technicians
- Atosa has manufacturing facilities totaling over 10 million square feet
- Atosa offers preventative maintenance programs
- Atosa offers delivery, install, and removal options
- Atosa products ship in robust packaging with breakaway skids
- All Atosa refrigeration ships with castors pre-installed
- Over 95% of Atosa's sales are from repeat business
- Atosa is continuously innovating and creating new solutions

Atosa's Exclusive Cleaning Solutions

We Clean The Kitchen Better!



Atosa is now offering a full line of cleaning solutions.

FOAMING DEGREASER (Non-Caustic)
Multi-use/multi-surface degreaser.

GRIDDLE CLEANER
Removes grease, fat and carbon buildup from hot surfaces, such as grills and griddles. Convenient one-time-use packets.

FRYER BOIL OUT
Concentrated fryer cleaner.
Low foaming tablets.
Food Grade degreaser.

DRAIN MAINTAINER
Uses bio-enzymes to clear sluggish drains, control odors, and deodorize drains without harming pipes.

COMBI OVEN BRIGHTENER
Reduces limescale buildup and ensures maximum rinse action for quick drying.

COMBI OVEN DETERGENT
Quickly emulsifies grease and food particles leaving your oven sparkling clean in one cycle. May be used as a spot cleaner to pre-treat heavy-duty soils.

COMBI OVEN STARTER KIT
Contains 32oz of Combi Oven Detergent and 32oz of Brightener. Great for new customers!

COIL CLEANER
This versatile product is formulated to offer the most effective, economical cleaning power currently available. No Persistent Bioaccumulative or Toxic Chemicals. No Ozone Depleting Compounds. Very Low Volatile Organic Compounds (VOC's). No SARA 313 Reportable Ingredients. No Phosphates. Contains safer ingredients, lowering the risk to children and adults from hazards like cancer, neurotoxicity and developmental effects.

ICE MACHINE POWDER DESCALER & POWDER RINSE
Descaler is used to remove limescale and mineral deposits. Rinse removes algae and slime. Easy to ship, store and transport. No partial package use, less waste & sustainable.

STANDARD FEATURES

Insulated Heater/Proofer/Warming Cabinets

- 9 Pan & 18 Pan Models
- S/S Exterior & Interior
- Full Electronic Controller
- Pre-Installed Casters & Slides

Countertop Heated Display Cases

- Curved & Square Models
- S/S Exterior & Interior With Black Frames
- Full Electronic Controller
- LED Lighting Standard
- S/S Shelves Standard
- Defog Feature For Glass
- 2 Rear Sliding Doors
- Removable Water Pan To Add Humidity

Electric Steam Tables

- S/S Exterior & Interior
- Insulated Open Wells
- Water Pans Standard
- Poly Cutting Board
- Optional Sneezeguard & Over Shelf



ATHC-9P
Half Size Warming Cabinet
Size: 25^{1/10} x 30^{7/10} x 42^{7/10}



ATHC-18P
Full Size Warming Cabinet
Size: 25^{1/10} x 30^{7/10} x 69^{7/10}



CHDC-56
Curved Countertop Heated Display Case
Size: 35^{3/8} x 22^{7/8} x 26^{3/4}



CHDS-71
Square Countertop Heated Display Case
Size: 35^{3/8} x 22^{1/2} x 26^{5/8}



CSTE-4C
4 Open Well Electric Steam Table
Size: 58 x 29^{1/2} x 33^{1/2}



MROS-4ST
Overshelf/Sneezeguard for CSTE-4C
Size: 58^{2/5} x 12^{1/5} x 16^{1/10}

STANDARD FEATURES

Ice Machines

- 142, 283, 350, 460 & 800 lb. Models
- S/S Exterior
- 1/2 Cube Ice
- 400 lb. & 700 lb. Ice Bins Available (For Modular Units)
- 350 lb. Hotel Ice Dispenser Available
- 3m Water Filter System Standard

STANDARD FEATURES

Deep Well Bottle Coolers

- S/S Exterior & Interior
- Full Electronic Controller
- Easy Glide S/S Lids With Handles
- Lid Locks Standard
- Bottle Opener & Cap Catcher
- Pre-Installed Casters & Wire Dividers

Keg Coolers

- S/S Exterior & Interior
- Dual Tap Towers Standard
- Fully Electronic Controller
- Door Locks Standard
- S/S Drip Tray
- Ball Valve & Manifolds
- Pre-Installed Casters & Shelves

Back Bar Coolers

- Solid & Glass Door Models
- Standard & Shallow Depth Models
- S/S Exterior & Interior
- Full Electronic Controller
- Pre-Installed Casters & Wire Dividers
- Door Locks Standard



YR140-AP-161
142 lb. Undercounter Ice Machine
Size: 23^{1/2} x 28^{1/2} x 38^{3/5}



YR800-AP-261
800 lb. Modular Ice Machine
Size: 30^{1/5} x 24^{9/20} x 31^{7/10}



CYR700P
700 lb. Ice Bin
Size: 48^{1/4} x 32^{1/2} x 41



MSCT-48-10
Refrigerated Countertop
Prep. Station
Size: 50^{1/10} x 15^{3/5} x 11^{4/5}



MKCD-23
Dual Refrigeration System
Beer Dispenser
Size: 23 x 31 x 50^{1/2}



MKC68GR
68" Direct Draw Keg Cooler
Size: 68 x 28^{1/10} x 40^{1/10}



HD350-AP-161
350 lb. Hotel Ice Dispenser
Size: 23 x 29^{1/2} x 70^{9/10}



MBGF48GR
48" Glass Froster
Size: 49^{2/5} x 26^{4/5} x 33^{3/5}



EBF-05
Blast Freezer
Size: 30 x 32^{1/10} x 34^{3/10}



MBC65GR
65" Bottle Cooler
Size: 64^{4/5} x 27^{4/5} x 36^{3/5}



MBB23GR
23" Back Bar Cooler
Size: 23 x 31^{1/10} x 39^{3/10}



MBB48GR
48" Back Bar Cooler
Size: 48 x 28^{1/10} x 40^{1/10}

Open Air Merchandisers & Display Cases

STANDARD FEATURES

Floor Model Refrigerated Square Display Cases

- 36", 48" & 60" Models Available
- S/S Exterior & Interior
- Two S/S Shelves
- LED Lighting Standard

Open Air Merchandisers

- Available In 40" & 50" Widths
- S/S Exterior & Interior
- Full Electronic Controller
- LED Lighting On Shelves & Top
- Night Curtain Standard
- Pre-Installed Casters & Shelves

Countertop Refrigerated Displays

- S/S Exterior & Interior With Black Frames
- Full Electronic Controller
- LED Lighting Standard
- S/S Shelves Standard
- Defog Feature For Glass
- 2 Rear Sliding Doors



AOM-50B
50" Open Air Merchandiser
Size: 51^{2/5} x 28 x 78^{7/10}



ATHOM-39
Horizontal Open Air Merchandiser
Size: 39^{1/10} x 34^{2/5} x 41^{1/5}



RDGS-48
Floor Model Refrigerated Display Case
Size: 47^{1/5} x 29^{1/2} x 47^{4/5}



CRDS-56
Square Countertop Refrigerated Display Case
Size: 35^{2/5} x 22^{1/10} x 26^{2/5}



CRDC-46
Curved Countertop Refrigerated Display Case
Size: 35^{2/5} x 22^{1/10} x 26^{2/5}



DSRC-28
Countertop Refrigerated Display Case
Size: 18^{7/10} x 16^{9/10} x 38^{3/5}

Merchandiser Coolers/Freezers

STANDARD FEATURES

Glass Door Merchandisers

- Coolers & Freezers
- Black & S/S Exterior Options
- S/S Interior
- Full Electronic Controller
- Pre-Installed Casters & Shelves
- Lighted Header Panels



MCF8733GR
Bottom Mount (2) Glass Door Black Merchandiser
Size: 39^{1/2} x 31^{1/2} x 81^{1/5}



MCF8723GR
Bottom Mount (2) Glass Door Black Merchandiser
Size: 54^{2/5} x 31^{1/2} x 81^{1/5}



MCF8727GR
Bottom Mount (2) Sliding Glass Door Black Merchandiser
Size: 54^{2/5} x 29^{7/10} x 81^{1/5}



MCF8705GR
Bottom Mount (1) Glass Door S/S Merchandiser
Size: 27 x 31^{7/10} x 83^{1/10}



MCF8707GR
Bottom Mount (2) Glass Door S/S Merchandiser
Size: 54^{2/5} x 31^{7/10} x 83^{1/10}

Reach-In Refrigerators/Freezers

STANDARD FEATURES

Reach-In Refrigerators/Freezers

- Top Mount & Bottom Mount
- S/S Exterior & Interior
- Full Electronic Controller
- Door Locks Standard
- Pre-Installed Casters & Shelves



MBF15FSGR
Slim (1) Door
Refrigerator

Size: 17^{7/10}×37×81^{3/10}



MBF8004GR
Top Mount (1) Door
Refrigerator

Size: 28^{7/10}×31^{7/10}×81^{3/10}



MBF8010GR
Top Mount (2) Half Door
Refrigerator

Size: 28^{7/10}×31^{7/10}×81^{3/10}



MBF8507GR
Bottom Mount (2) Door
Refrigerator

Size: 54^{2/5}×31^{7/10}×83^{1/10}



MBF8005GR
Top Mount (2) Door
Refrigerator

Size: 51^{7/10}×31^{7/10}×81^{3/10}



MBF8011GR
Top Mount (4) Half Door
Refrigerator

Size: 51^{7/10}×31^{7/10}×81^{3/10}



MBF8506GR
Slim (2) Door
Refrigerator

Size: 39^{1/2}×31^{7/10}×83^{1/10}



MSF8302GR
48" Refrigerated Standard Top
Sandwich Prep. Table **New Design!**

Size: 48^{1/5}×30×44^{3/10}



MPF8202GR
67" Refrigerated Pizza Prep. Tables
With New Drawer Cartridge!

Size: 67×33^{1/10}×44



MSF8308GR
72" Refrigerated Mega Top
Sandwich Prep. Table **New Design!**

Size: 72^{7/10}×34×47^{1/10}

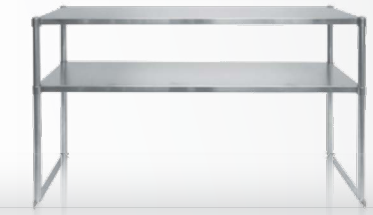

MROS-67P
67" Double Overshelves for
Pizza Prep. Tables

Size: 67×14×47^{1/5}



MROS-4RE
48" Double Overshelves for
Sandwich Prep. Tables

Size: 48^{1/4}×12^{4/5}×33

Refrigerated Prep Tables

STANDARD FEATURES

Sandwich Prep Tables

- Standard & Mega Top Models
- S/S Exterior & Interior
- Full Electronic Controller
- Pans Standard
- Pre-Installed Casters & Shelves
- Optional Drawer Cartridges

Pizza Prep Tables

- S/S Exterior & Interior
- Full Electronic Controller
- Pans Standard
- Pre-Installed Casters & Shelves
- Optional Drawer Cartridges

Overshelves

- 18 Gage Stainless Steel
- Top & Bottom Shelves Are Sound Deadened
- NSF Approval
- Available On Sandwich & Pizza Prep Models

Undercounter Refrigerators/Freezers

STANDARD FEATURES

Undercounter Refrigerators/Freezers

- Refrigerators & Freezers
- S/S Exterior & Interior
- Full Electronic Controller
- Pre-Installed Casters & Shelves

FIELD INSTALLABLE DRAWER ASSEMBLY KIT



MGF24RGR
24" Undercounter
Refrigerator
Size: 23^{13/16} x 25 x 32^{1/2}



MGF8405GRL
27" Undercounter Freezer
Left Hinged
Size: 27^{1/2} x 30 x 34^{1/5}



MGF8415GR
27" Undercounter Refrigerator
w/ 2 Drawers
Size: 27^{1/2} x 30 x 34^{1/5}

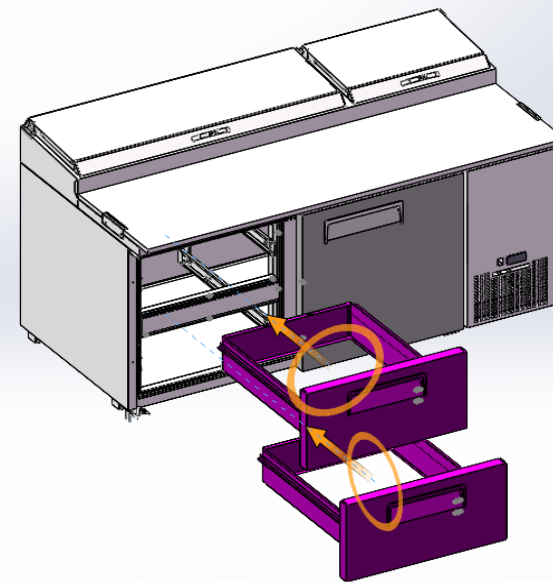

MGF36RGR
36" Undercounter
Refrigerator
Size: 35^{9/10} x 30 x 34^{1/5}



MGF8402GR
48" Undercounter
Refrigerator
Size: 48^{9/10} x 30 x 34^{1/5}



MGF8402GR
48" Undercounter Refrigerator
With New Drawer Cartridge!
Size: 48^{9/10} x 30 x 34^{1/5}



DRAWER ASSEMBLY KIT INCLUDES

- 4 Brackets
- 2 Rails
- 1 Mullion
- 2 Drawers

AVAILABLE IN THE FOLLOWING SERIES

- Refrigerated Pizza Prep. Tables
- Refrigerated Sandwich Prep. Tables
- Worktop/Undercounter Refrigerators/Freezers



Worktop Refrigerators/Freezers & Chef Bases

STANDARD FEATURES

Worktop Refrigerators/Freezers

- Refrigerators & Freezers
- S/S Exterior & Interior
- Full Electronic Controller
- Pre-Installed Casters & Shelves

Refrigerated Chef Bases

- S/S Exterior & Interior
- Pans Standard
- Heavy Duty Drawer Slides & Rollers
- Flat Top with Corner Guards
- Pre-Installed Casters



MGF8412GR
27" Worktop Freezer
with Backsplash
Size: 27^{1/2} x 30 x 39^{4/5}



MGF8409GR
48" Worktop Refrigerator
with Backsplash
Size: 48^{3/10} x 30 x 39^{4/5}



MGF8410GR
60" Worktop Refrigerator
with Backsplash
Size: 60^{1/5} x 30 x 39^{4/5}



MGF8448GR
36" Refrigerated Chef Base
Size: 35^{5/5} x 33 x 26^{3/5}



MGF8450GR
48" Refrigerated Chef Base
Size: 48^{2/5} x 33 x 26^{3/5}

Walk-In Coolers/Freezers



AWCO0808
Walk-in Cooler
Size: 8' x 8' x 7' 7"



STANDARD FEATURES

- * 20% more efficient than any walk-in series on the market
- * Available in nominal sizes from 6' X 6' up to 10' X 14' all 7'7" high with floor (7'2" floorless height) - indoor models only
- * Foamed-in-place 4" panels with cam locks
- * Top mount low noise level drop in refrigeration systems - environmentally friendly R448A refrigerant
- * Coolers available with or without a floor (freezer floor standard)
- * 3 spring-loaded heavy duty door hinges standard
- * 34" door standard with diamond tread kick plates and heated frames
- * Heavy-duty door closer
- * Heavy-duty door handle with lock and inside safety release
- * Exterior ramp standard
- * Digital LED display
- * Robust reinforced floor
- * High output, low profile LED light standard above the door - optional 48" ceiling mount LED
- * Coolers maintain 33 - 38 degrees, freezers maintain 0 - 10 degrees



Floor Screed for Floorless Walk-in



High Output LED Light



Condensing Unit & Evaporating Unit



Keyed Locking Door Handle



Heavy Duty Door Closer



Triple Heavy Duty Door Hinges



Digital LED Thermometer & Switch



Heated Pressure Relief Vent



Insulated Floor w/ NSF Approved Radius

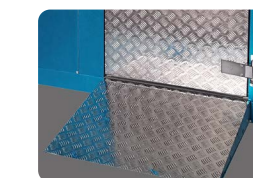

Exterior Ramp

Intelligent French Fry Robotic Solution

[CLICK FOR VIDEO](#)



Freezer/Fry Dispenser
FFD45 – French fry freezer with hopper and dispenser.



Ansul Fire Suppression System



Dump Station
FATFW36 – warmer/holding cabinet w/ heat lamp & product diverter.



Robotic Arm
CR10 – 6-axis co-bot w/ a reach range of 51”+ including an AC100 control panel.

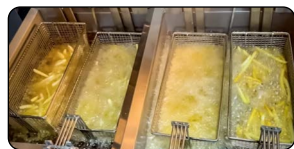

Fryer Battery
ADFB-50 – double 50 lb. fryers w/ full electronic controls & built in filtration system.



Hood Assembly
HDAR – ventless hood assembly w/ Ansul Fire Suppression system.

Atosa Smart Touch Combi Ovens



Designed for maximum steam saturation and humidity

10” Smart screen with chef touch controls

Twin fill tanks

Smart touch rack timing

Sub-divided heating system for maximum recovery

Wi-Fi connection, self diagnostics and service diagnostics

Perfect humidity control

Combi smart touch processes

6 Mode automated combi wash with high pressure coil wash hose

Atosa Combi smart cooking

8 Fan speed balance reverse

USB storage



STANDARD FEATURES

Countertop Convection Ovens

- S/S Exterior & Interior
- Quarter, Half & Full-Size Models
- Chrome Oven Racks
- Double Pane, Re-enforced Door
- 100 – 500 Degree Temperature Range
- 120 Minute Timer

Manual & Thermostatic Griddles

- S/S Exterior & Interior
- 3/4" Plate (Manual) 1" Plate (T-Stat)
- Manual Or Thermostatic Controls
- S/S Grease Drawer
- 25,000 BTU Burners
- S/S Legs

Radiant & Char-Rock Broilers

- S/S Exterior & Interior
- 35,000 BTU Burners
- Independent Manual Controls
- Heavy-Duty, Cast-Iron Grates
- S/S Legs

STANDARD FEATURES

Gas Fryers

- S/S Exterior & Interior
- 35, 40, 50, & 75 lb. Models
- New 35 lb. Energy Star Fryer
- 5-Year Tank Warranty
- Millivolt Controller
- Casters Standard



ATMG-24
24" Manual Griddle
Size: 24x28^{3/5}x15^{1/5}



ATTG-24
24" Thermostatic Griddle
Size: 24x28^{3/5}x15^{1/5}



ATRC-36
36" Radiant Broiler
Size: 36x27^{3/5}x15^{1/5}



ATFS-35ES
35 lb. Fryer
Size: 15^{3/5}x30^{1/10}x44^{2/5}



ATFS-50
50 lb. Fryer
Size: 15^{3/5}x30^{1/10}x44^{2/5}



ATFS-75
75 lb. Fryer
Size: 21^{1/10}x30^{1/10}x44^{2/5}



ACHP-6
36" (6) Burner Hot Plate
Size: 36x27^{3/5}x13^{1/10}



CTCO-100
Countertop Convection Ovens
Size: 31^{13/16}x27^{3/32}x23^{5/32}



ATSE-3036
30"x36" S/S Equipment Stand
Size: 36x30x24

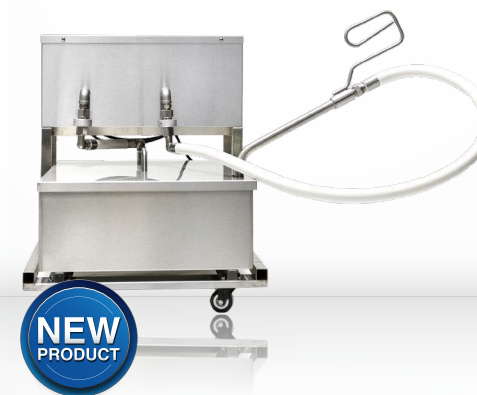

FPOF-80
80 lb. Portable Fryer Filter
Size: 20^{1/5}x33^{1/2}x24



FPOF-50
50 lb. Portable Fryer Filter
Size: 15^{3/5}x30^{1/10}x44^{2/5}

Gas Ranges & Convection Ovens

STANDARD FEATURES

Gas Ranges

- 4, 6, 8, & 10 Burner Models Available
- S/S Exterior & Enamel Interior
- 32,000 BTU Burners
- 2 Oven Racks Standard
- Casters Standard

Standard & Bakery Depth Convection Ovens

- Single & Double Stacked
- S/S Exterior & Enamel Interior
- Solid State Controller With Cook & Hold
- 5 Oven Racks Standard Per Oven
- 50/50 Dependent Doors



AGR-6B24GR
60" Gas Range (6) Burner and 24" Griddle
Size: 60x31x57^{3/8}



AGR-6B
36" Gas Range (6) Burner
Size: 36x31x57^{3/8}



AGR-6B-24RGB
60" Gas Range w/ (6) Burner and 24" Raised Griddle/Broiler
Size: 60x31x57^{3/8}



ATCM-36
36" Cheesemelter
Size: 36x18 x17^{1/3}



ATCO-513B-1
Single Bakery Depth Convection Oven
Size: 38^{1/5}x45x59^{2/5}



ATCO-513NB-2
Double Stacked Standard Depth Convection Oven
Size: 38^{1/4}x42x69

EXTENDED WARRANTIES NOW AVAILABLE



ATOSA HAS YOU COVERED!

Up To 5 Years Parts & Labor On All Refrigeration, Cooking Equipment, Ice Machines & Steam Tables



Atosa Core Values

Unmatched Quality, Value, and Service Which is why we are pleased to offer extended warranties

Give Yourself Peace of Mind

Extended your warranty to a full 5-year parts and labor warranty for less than the cost of one service call

Atosa Standard Warranties

Refrigeration & Ice Machines - 2 years parts & labor, 5 years compressor
Cooking Equipment & Steam Tables - 1 year parts & labor



Toll Free: 855-855-0399 | Email: info@atosausa.com | www.atosausa.com